

S211

Capacity: 2560 CFM@ 4 in.W.G.

Motor: 1.5 HP, Direct Drive

Voltage: Single Phase, 110V 60Hz

Full Load Amps: 20.0 (110V)

Sound Level: 72 dBA

Cabinet Dimensions (HxLxD): 52" x 61" x 29"

Weight: 700 lbs.

Filter Media Area: 284 sq. ft. total

Standard Equipment Features

Blower: Reverse inclined high performance blower wheel

Silencing: Integral Acoustical Plenum with Low Frequency Dampening

Controls: Manual on/off switch, Minihelic Filter Condition Gauge

Filter Cartridge: PleatLock A15 Vertical Filter-(2) PL-18D12-A15-C

Filter Type: Nanofiber MERV 15

Dust Containment: Vacuum/sweep out filter plenum

Spark Arrestance: Triple Layer, (2) FB-24242, (4) MM-24242

Configurations: Table Size: 60" x 36", 1 x 1/8 bar grating, 630 lb. load capacity

Heavy Duty Construction: Fully welded 7 & 11 gauge steel

Metal Mesh Filter

US Duct Spark Trap

Warranty: Visit ventboss.com/terms for full warranty details

Optional Equipment Features

Filter Cleaning: On board compressed air tank, manual activated push-button filter pulse cleaning, 3/4"NPT compressed air connection

Caster Wheel Kit: WK-S200

CSA Certification: CSA-100

UL Certification: Contact Customer Service

Custom Color

Endurex B16 Filter

PleatLock M11 filter

After Filter

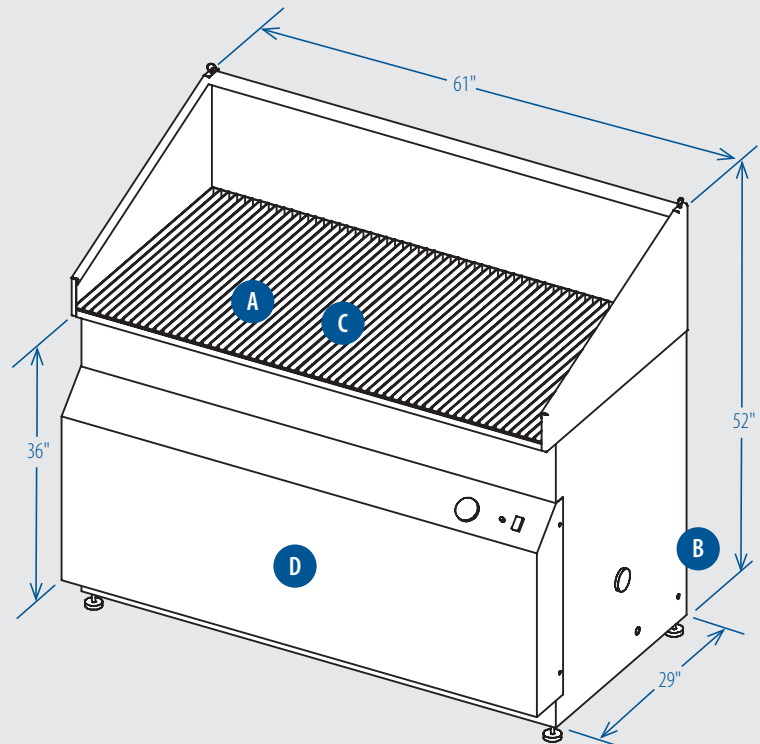

A Inlet Area

B Clean Air Exhaust (on back)

C Filter & Spark Arrestance Access

D Particulate Clean-Out

This system is covered by one or more of the following patents: #6,758,875; #4,610,704 and other patents pending. Due to continued engineering, all specifications are subject to change without notice.
©2016 RoboVent Product Group, Inc. 06/2016