

MODEL

S230



Maximum filter life will be achieved with this product when one welder is welding up to 25 pounds of weld wire per week, great for educational facilities as they can sit back to back and side to side



Capacity: 2000 CFM @ 3.5 in.W.G.

Motor: 2 HP, Direct Drive

Voltage: 3 Phase, 480V, 60Hz

Full Load Amps: 3.4

Blower: Reverse inclined high performance blower wheel

Sound Level: 72 dBA

Silencing: Integral Acoustical Plenum with Low Frequency Dampening

Controls: Manual on/off switch, Minihelic Filter Condition Gauge

Cabinet Dimensions (HxLxD): 90" x 60" x 44"

Weight: 700 lbs.

Filter Cartridge: (1) PL-22D14-A15-C

Filter Media Area: 234 sq. ft.

Filter Type: Nanofiber MERV15

Filter Cleaning: On board compressed air tank, manual activated push-button filter pulse cleaning, 3/4"NPT compressed air connection

Dust Containment: Vacuum / sweep out filter plenum

Spark Arrestance: One Layer, (1) MM-17402

Configuration: Table Size: 30"D x 60"W

Options:

- Curtain Kit — VB-CRT
Weld flash curtain kit includes: curtain, hang bar and brackets
- Light Kit — VB-LK
- 110V Plug & 480V Connection for Welder — PL-110V-480V
- CSA Certification — CSA-100
- UL Certification — Contact Customer Service
- Other Voltages: 230V or 575V

Warranty:

Visit ventboss.com/terms for full warranty details.

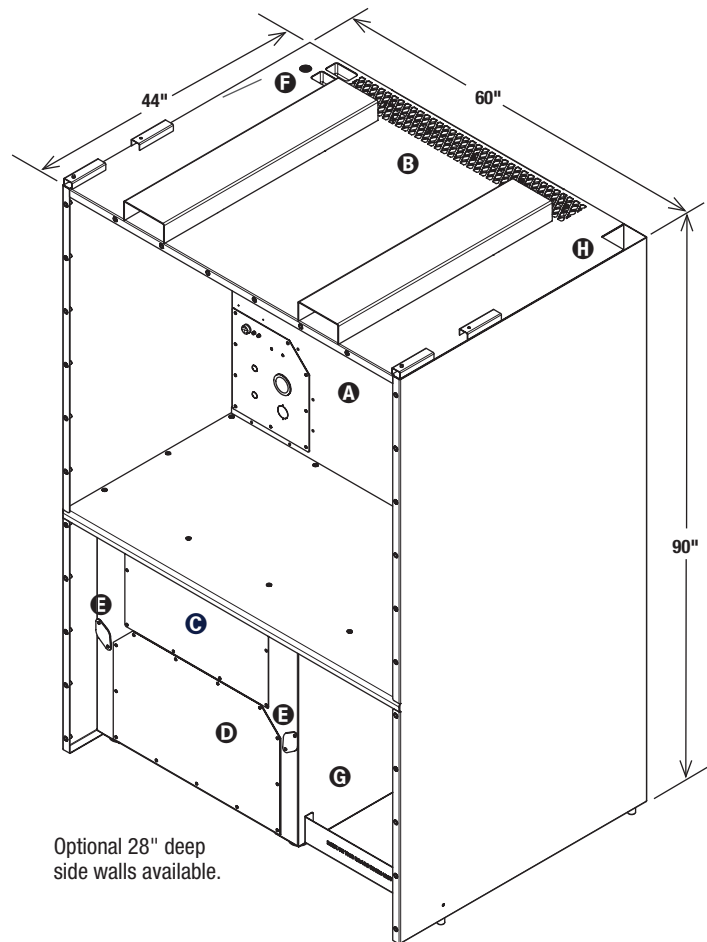

Optional 28" deep side walls available.

- Ⓐ Inlet Area
- Ⓑ Clean Air Exhaust
- Ⓒ Filter Access
- Ⓓ Motor
- Ⓔ Particulate Clean-Out
- Ⓕ Electrical/Air Hookup
- Ⓖ Welder Placement Area
- Ⓗ Power Access Channel to Welder Area