

### RDC-1X4-4C

**Dimensions w/ intake(s):** 36D" x 87W" x 203H"

**Base Weight:** 4,140 lbs.

*Includes base collector & HLL containment*

**CFM:** 8,000

**HP:** 20

**Full Load Amps @ 480 V:** 27 FLA

**Static Pressure:** 10 in. wg

**Filter Cartridges:** (4) PL-14D52-A15-SF21

**Comparable Filter Media:** 1,860 sq. ft.

#### Equipment

#### Video Link

**Controls:** ePro 7" touchscreen for ease of use.

**Heavy Duty Construction:** Fully welded 7 & 11 gauge steel

**Pulsing System:** 16 SCFM

**Filter Design:** Included as standard to improve filter life and reduce energy consumption

**Blower/Motor Combination:** Designed for energy efficiency

**SafeSensor Particulate Monitor:** Detects leaks past the filters

**Air Intake:** Reduces airspeed allowing heavy dust to fall away from filters.

- SAP: Metal mesh/baffle intake - Standard
- Ducted Intake: Optional

**Warranty:** 15 years on the cabinet; 5 years on components (See warranty document for details)

**Fire Suppression (optional):** FM-200, CO<sub>2</sub>, water

**Vortex Plenum:** With adjustable nozzles

**After Filters (optional):** HEPA\* or active carbon

**Containment:** Various containment options including a dust tray, HSL, HLL

**ICE Package (optional):** Air conditioning coil and condenser package

*\*HEPA filters option reduces airflow down to 2,600 CFM*

#### Specifications

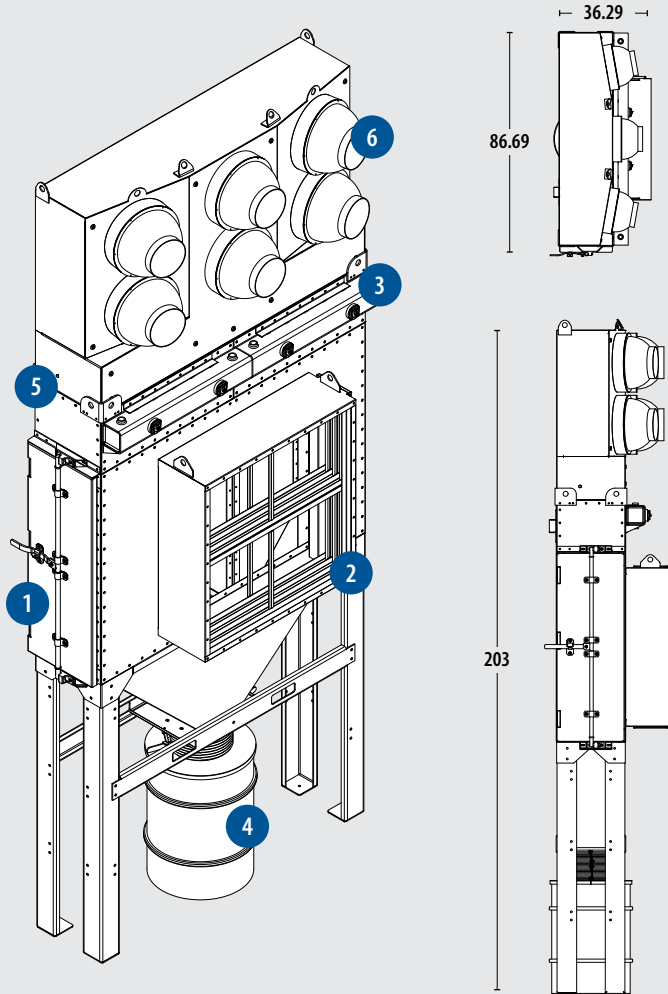

- 1 Filter Cabinet Assembly
- 2 Air Intake
- 3 Advanced Pulsing System
- 4 Dust Containment Options (HLL Shown)

- 5 SafeSensor Particulate Monitor
- 6 Vortex Top Plenum: Exhaust Plenum with Adjustable Louvers